

BUTTON HEAD CABLE TIES



BUTTON HEAD CABLE TIES

Designed to securely attach bundle to chassis while allowing removal prior to tightening

- Provides parallel entry and exit through the button head
- Serrations on both sides of cable tie and two opposed pawls allow for clockwise or counter-clockwise installation
- Heat stabilized to provide high operating temperatures of 230°F
- Impact resistant material resists high impact fatigue and endures vibrations
- Weather resistant UV black for outdoor use and sun protection

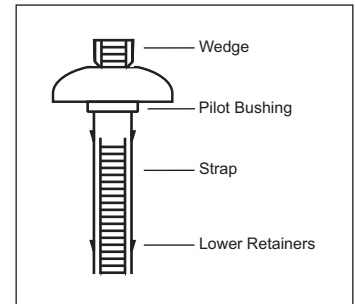

ACT Part Number	Length Inch/mm	Width Inch/mm	Thickness Inch/mm	Pilot Bushing Diameter Inch/mm	Pilot Bushing Thickness Inch/mm	Head Diameter Inch/mm	Head Height Inch/mm	Tensile Strength lb/n	Max Bundle Dia. In/mm	Per Bag	Per Case
AL-08-120-BH-IT-30-C	7.87/200.0	0.30/7.60	0.065/1.65	0.43/10.9	0.079/2.0	0.952/24.18	0.276/7.0	120/534	2.00450.9	100	2000
AL-11-120-BH-IT-30-C	11.81/300.0	0.30/7.60	0.065/1.65	0.43/10.9	0.079/2.0	0.952/24.18	0.276/7.0	120/534	3.25/82.8	100	1500
AL-14-120-BH-IT-30-C	14.56/370.0	0.30/7.60	0.065/1.65	0.43/10.9	0.079/2.0	0.952/24.18	0.276/7.0	120/534	4.07/103.5	100	1000

COO: CN

Sold in case quantities

Related product lines



Heat Stabilized
UV Black Nylon 66



Spiral Wrap



Dual Loop
Cable Ties

ACT
ADVANCED CABLE TIES, INC.
245 Suffolk Lane, Gardner, MA 01440
Phone: 800.861.7228 - Fax: 978.630.3999
sales@actfs.com

